

NOTES:

1. **This Standard Plan shall only apply to streets that are exempt from the City of Tacoma's Restoration Policy. See Standard Plan SU-14B for any streets not exempt from this policy.**
2. Temporary Surface Restoration:
Arterials, industrial areas and/or roads with bus traffic: Temporary patches shall be compacted and leveled to a minimum of 3-inches of hot-mix asphalt (HMA).
Residential and alleys: Temporary patches shall be compacted and leveled to a minimum of 2-inches of either hot-mix asphalt or cold-mix asphalt.
 Temporary patches between October 1st and March 31st shall be made with hot-mix asphalt unless otherwise approved.
3. All permanent final patches shall be rectangular in shape and constructed parallel and perpendicular to the road centerline.
4. Where existing pavement defects are in close proximity to the new cut, the inspector may require additional pavement removal to eliminate the pavement defect.
5. The final cut edge of paved surfaces shall be smooth and straight, consistent with grinding or saw cutting devices. No jagged, broken or undermined edges are allowed. Cutting wheel run-out beyond the limits of the opening shall be filled in accordance with WSDOT Standard Specification 5-05.3(8)B for cement concrete surfaces and 5-04.3(5)C for asphalt concrete surfaces.
6. Final compaction of HMA shall be 91% of maximum density.
 Testing shall be performed by a certified independent testing laboratory or certified tester, as approved by the City's Construction Division. Tests shall be completed and reports identifying the project number submitted to the City Construction Division within 48 hours of test.
7. All joints between the new and original asphalt pavement shall be sealed with hot asphalt or asphalt emulsion and covered with dry paving sand before the asphalt solidifies. Existing surfaces shall be prepared in accordance with WSDOT Standard Specification 5-04.3(5)A prior to placing any new pavement surfaces.

8. For municipal capital improvement projects, cement concrete base pavement shall be in accordance with WSDOT Standard Specification 5-05 for cement concrete pavement. For non-municipal capital improvement projects, concrete shall be a minimum compressive strength of 4,000 PSI.

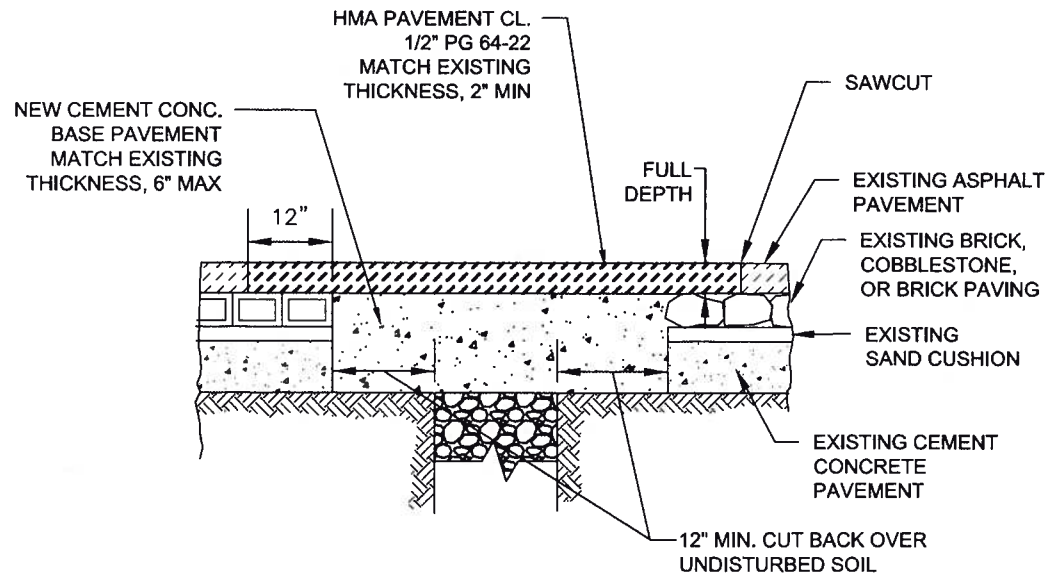

APPROVED FOR PUBLICATION

CITY OF TACOMA
DEPARTMENT OF PUBLIC WORKS

[Signature]
CITY ENGINEER

11/20/10
DATE

TYPICAL PAVEMENT RESTORATION FOR
ASPHALT OVER RIGID BASE BRICK
OR STONE BLOCK PAVEMENT

STANDARD PLAN NO. SU-14E