

NOTE:  
 THE NORTH SLOPE STANDARD PLANS ARE  
 INTENDED TO PROTECT ELEMENTS OF HISTORIC  
 SIGNIFICANCE IN ACCORDANCE WITH CHAPTER  
 13.07 OF THE TACOMA MUNICIPAL CODE.

APPROVED FOR PUBLICATION

CITY OF TACOMA  
 DEPARTMENT OF PUBLIC WORKS

*James Peck*  
 CITY ENGINEER

19 May 2009  
 DATE

NORTH SLOPE HISTORIC DISTRICT  
 SITE MAP

STANDARD PLAN NO. HD-NS01



**NOTES:**

1. Sidewalks shall be designed and constructed in accordance with ADA Standards for Accessible Design, 28 CFR, Part 35 and as supplemented by the Public Right of Way Accessibility Guidelines (PROWAG).
2. Staking is required where no curb is present.
3. All expansion joints shall be full depth with 3/8" premolded joint filler.
4. All joints shall be cleaned and edged. External edges shall be 1/2" radius. Internal joints shall be 1/4" radius.
5. All soft and yielding foundation material shall be removed and replaced with crushed surfacing top course (CSTC) meeting the requirement of Section 9-03.9(3) of the WSDOT Standard Specifications.
6. All sidewalk shall be replaced to the nearest expansion or contraction joint. All joints shall be saw cut full depth prior to restoration and 3/8" expansion joint installed. Cutting wheel run-out beyond the limits of the opening shall be filled in accordance with WSDOT Standard Specification 5-05.3(8)B for cement concrete surfaces and 5-04.3(5)C for asphalt concrete surfaces.
7. Apply lamp black 1lb. per cubic yard of cement concrete or as required for desired discoloration in accordance with ASTM D209-81 standard specification for lamp black pigment.

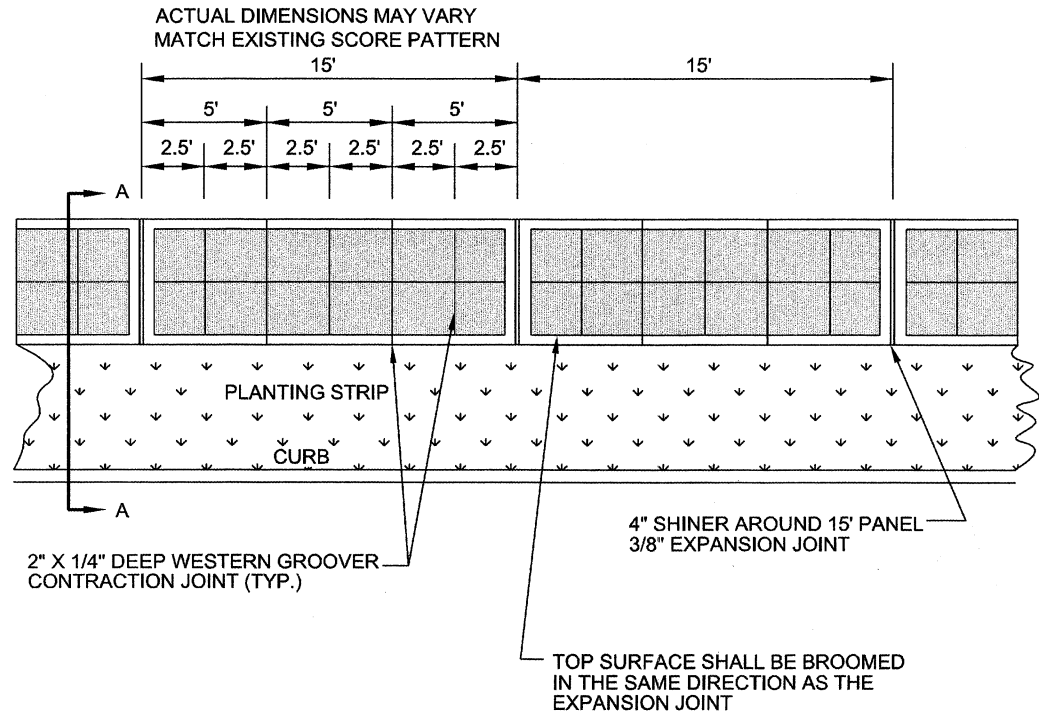
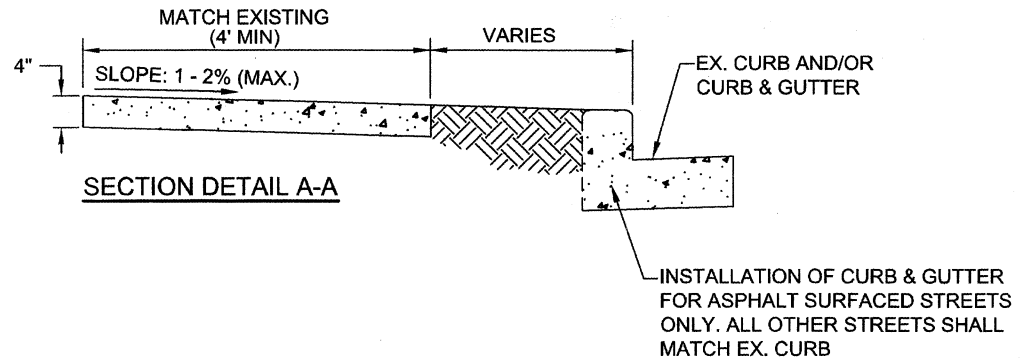

<p><b>CITY OF TACOMA</b> <b>DEPARTMENT OF PUBLIC WORKS</b></p>	<p><b>APPROVED FOR PUBLICATION</b></p> <p style="text-align: right; margin-right: 20px;"><i>[Signature]</i> CITY ENGINEER</p> <p style="text-align: right; margin-right: 20px;">12/6/15 DATE</p>	<p><b>NORTH SLOPE HISTORIC DISTRICT</b> <b>CEMENT CONCRETE</b> <b>SIDEWALK</b></p> <p><b>STANDARD PLAN NO. HD-NS03</b></p>
--	--	--

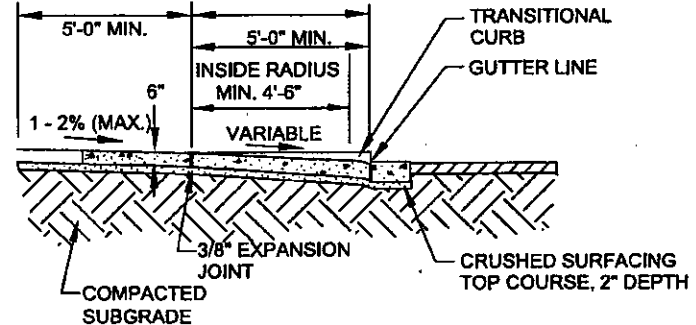
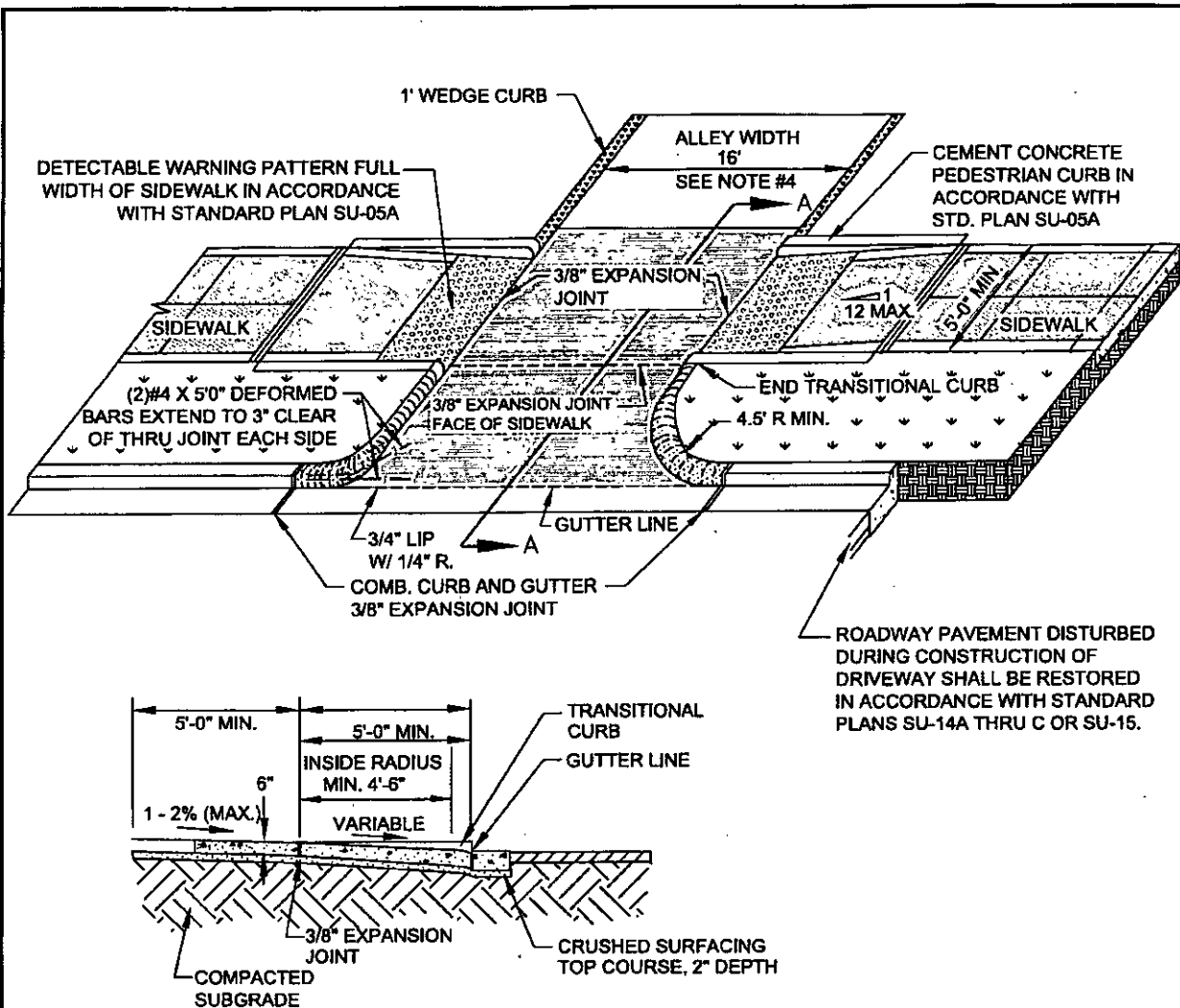

**SECTION DETAIL A-A**

**NOTE:**  
 TYPE 3 DRIVEWAY SHALL BE USED AT ALLEYS WHERE THE PLANTING STRIP IS 5' WIDE OR GREATER

- NOTES:**
1. All driveways shall be approved by the Tacoma Landmark Preservation Commission.
  2. Concrete shall be a minimum of Class 3000.
  3. All joints shall be cleaned & edged. External joints to the driveway shall be 1/2" radius. Internal joints to the driveway shall be 1/4" radius.
  4. Driveways wider or narrower than shown on this plan require approval of the Director of Public Works.
  5. 6" thick driveway section shall be a brushed finish in a transverse direction to the center line of the driveway.
  6. Driveways wider than 20' require a center line expansion joint.
  7. All expansion joints shall be full depth with 3/8" premolded joint filler.
  8. When trenching through a driveway, replacements for driveways greater than 20' in width shall include a minimum 3' wide cut back over undisturbed soil and extend to the nearest control joint. Replacements for driveways 20' or less in width will require a full driveway replacement.
  9. All joints shall be saw cut full depth prior to restoration and 3/8" expansion joint installed. Cutting wheel run-out beyond the limits of the opening shall be filled in accordance with WSDOT Standard Specification 5-05.3(8)B for cement concrete surfaces and 5-04.3(5)C for asphalt concrete surfaces.
  10. Where distance from face of curb to front face of walk exceeds 12', a transverse joint shall be placed at the radius point or as directed by the engineer.
  11. Driveways shall be placed before roadway restoration pavement.
  12. Apply lamp black 1lb. per cubic yard of cement concrete or as required for desired discoloration in accordance with ASTM D209-81 standard specification for lamp black pigment.

<p>CITY OF TACOMA          DEPARTMENT OF PUBLIC WORKS</p>	<p>APPROVED FOR PUBLICATION</p> <p><i>Jana Parvey</i>          CITY ENGINEER</p> <p>19 May 2009          DATE</p>	<p>NORTH SLOPE HISTORIC DISTRICT          ALLEY ENTRANCE</p> <p>STANDARD PLAN NO. HD-NS04</p>
---	---	---

**NOTES:**

- ① Intercept existing conduit, where applicable, and route toward light standard. Terminate conduit(s) approximately 12" from base of standard. Seal end of conduits with tape.
- ② Coil three feet of wire at end of conduit before entering base of standard.
- ③ Route wire up to terminal block without splicing.
- ④ Minimum auger size is 12". Backfill with crushed surfacing top course. tamp in 6 inch lifts.
- ⑤ Square pole to curb  $\pm 3$  degrees.

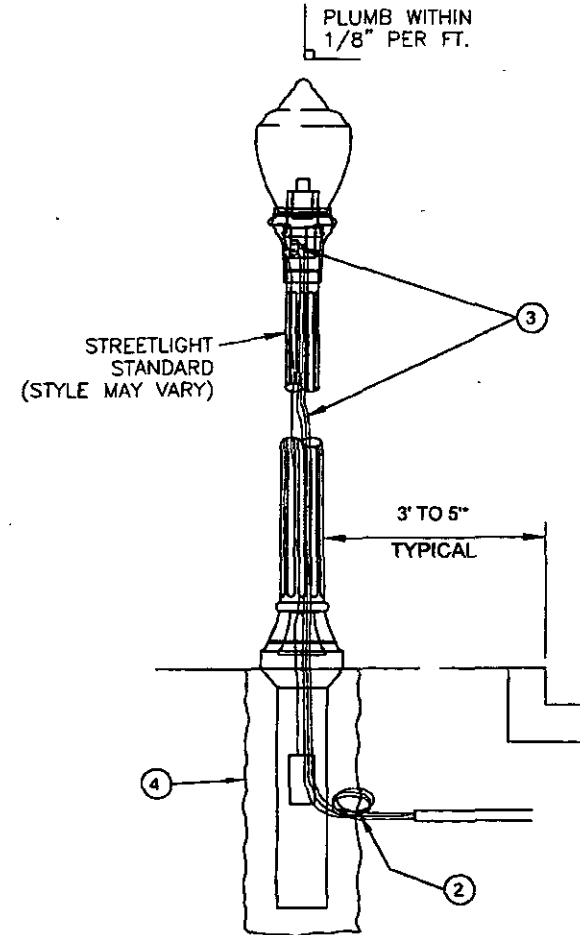
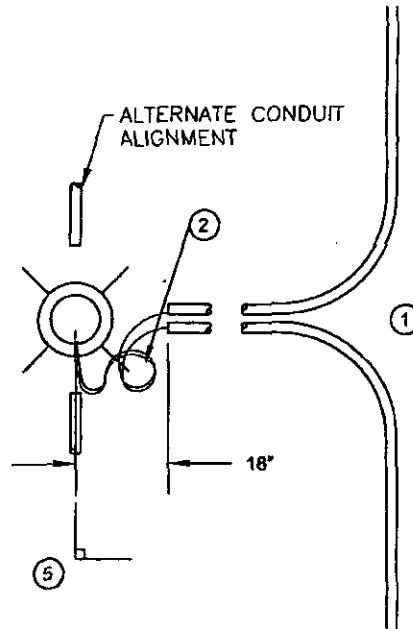

\* OR AS DETERMINED BY ENGINEER

APPROVED FOR PUBLICATION

CITY OF TACOMA  
DEPARTMENT OF PUBLIC WORKS

*James Parvly*  
CITY ENGINEER

*19 May 2009*  
DATE

NORTH SLOPE HISTORIC DISTRICT  
STREETLIGHT

STANDARD PLAN NO. HD-NS05