



THIS IS NOT AN ORDER
All prices quoted shall be F.O.B.
Destination, Freight Prepaid and Allowed

All responses & inquiries must be plainly marked with this

**REQUEST FOR QUOTATION
6000039868**

Return Bids By 11:00 AM, 04/16/2015 to:

Samol P Hefley
 S Hefley
 TPU Administration Building North
 3628 S. 35th St.
 Tacoma WA 98409
 Ph. 253-502-8249
 Fax.253-502-8372

Material will ship to:

Generation
 Tacoma Power
 3628 S 35th Street
 Tacoma WA 98409

RFQ Information	
Collective Bid #	PG15-0256N
Bid Issue Date	04/08/2015
Vendor Number	109226 WEB VENDOR FOR RFQ
Vendor Information (vendor to complete)	
Firm Name:	
Address:	
City/State/Zip	/ /
Phone/Fax	/
E-Mail	
Contact Name	
Payment Terms	%, days (e.g. 2% 10,N30)
Tacoma Bus. Lic. #	
Taxpayer ID #	
SIGNATURE OF PERSON AUTHORIZED TO SIGN THIS BID	
x _____	DATE: ___ / ___ / _____
NAME :	_____
TITLE :	_____

Item #	Material# Description	Delivery Date	QTY	UM	Net Price	Total
	<p><u>***The City of Tacoma will accept e-mailed bid submittals sent to sendbid@cityoftacoma.org for this solicitation. Please include the Collective Bid Number in the subject line of your e-mail. Bids are subject to the submittal deadline noted in the bid solicitation document. The time of e-mail receipt will be considered as the time of submittal. <u>Submittals are accepted by one of the following delivery methods:</u> e-mail, facsimile, or mail. The City accepts no responsibility for transmission errors.</u></p> <p>The City of Tacoma is soliciting bids for Antique Acorn Style Light Fixtures for Cushman Dams.</p> <p>Responses must be submitted on the provided City of Tacoma bid solicitation form. Vendor signature is mandatory.</p> <p>All bid pricing shall be FOB Destination, freight prepaid and included in the unit price.</p> <p>Any bidder may be notified to clarify their bid proposals. This action shall not be construed as negotiations or an indication of intentions to award. The bidder must be able to provide the information within two</p>					



CITY OF TACOMA

THIS IS NOT AN ORDER
All prices quoted shall be F.O.B.
Destination, Freight Prepaid and Allowed

All responses & inquiries must be plainly marked with this

REQUEST FOR QUOTATION 6000039868

Item #	Material# Description	Delivery Date	QTY	UM	Net Price	Total
10	<p>(2) business days.</p> <p>Technical questions: Steve Fischer, 253-502-8316 sfischer@cityoftacoma.org</p> <p>Purchasing related questions: Samol Hefley, 253-502-8249 shefley@cityoftacoma.org</p> <p>Items must be new and unused.</p> <p>Antique Acorn Style Light Fixtures Traditional acorn style fixtures with decorative cast aluminum fitters (polyester powder baked coating), and acrylic white acorn globes. Per attached product specifications</p> <p>Fitters, globes and lights shall be (or approved equal): Sternberg B750AW/5PPT (mod to fit 2.875" OD tenon)/XRLED-12L45T3-MDL14/BK,(OWG,old world grey)</p>		33	EA		

Net Value	\$
Plus Tax at	
_____ %	\$
Total Amount	\$

CITY OF TACOMA
REQUEST FOR QUOTATION
GENERAL TERMS AND CONDITIONS

1. Preparation/Submittal of Bids

A. All information requested of the Bidder/Proposer must be entered in the appropriate space on the form. Failure to do so may disqualify your bid/proposal.

B. All information must be written in ink or typewritten. Mistakes may be crossed out and corrections inserted before submission of your bid/proposal. Corrections shall be initialed in ink by the person signing the bid/proposal.

C. Time of delivery must be stated as the number of calendar days following receipt of the order by the Bidder/Proposer to receipt of the goods or services by the City and may be a determining factor in the award of the contract.

D. All bids/proposals must be signed by an authorized officer or employee of the Bidder/Proposer.

E. The City of Tacoma will not be responsible for any explanation interpretation of the RFB/RFQ/RFP documents, except if made by written addendum.

F. Bids/Proposals must be submitted by or prior to the RFB/RFQ/RFP date and time specified. The RFB/RFQ/RFP number, opening date and Buyer must be noted on the face of the envelope if submitted by mail or in person.

G. Submission of a facsimile bid/proposal in lieu of a mailed bid/proposal is at the option of the Bidder/Proposer unless otherwise stated in the RFB/RFQ/RFP. The City accepts no responsibility for transmission errors if transmitted by fax.

H. All bid/proposal prices must remain firm for acceptance by the City for a period of at least 60 calendar days from the RFB/RFQ/RFP opening date.

2. Bid/Proposal Withdrawal: No bid/proposal can be withdrawn after having been formally opened by a representative from the City Purchasing Office.

3. Shipping and Delivery: F.O.B. Point/Freight: All prices quoted shall be F.O.B. destination, freight prepaid and allowed. Failure to meet this requirement may result in your bid/proposal being rejected as non-responsive. Deliveries will be accepted between 9:00 a.m. and 3:30 p.m., at the delivery address shown on the front of the RFB/RFQ/RFP, Monday through Friday (except on legal holidays of the City of Tacoma).

4. Payment Terms: Prices will be considered as net 30 if no cash discount is shown. Payment discount periods of twenty (20) calendar days or more will be considered in determining the apparent lowest responsible bid/proposal. Invoices will not be processed for payment nor will the period of the cash discount commence until receipt of a properly completed invoice and until all invoiced items are received and satisfactory performance of the contractor has been attained. If an adjustment in payment is necessary due to damage or dispute, the cash discount period shall commence upon the final approval for payment.

5. Terms and Conditions: All terms and conditions of the City of Tacoma Purchase Order form shall apply to contracts resulting from this RFB/RFQ/RFP.

6. Taxes:

A. The City of Tacoma is exempt from Federal excise tax.

B. The City of Tacoma is subject to Washington State Sales Tax.

C. Section 6A.30.060 of the Tacoma Municipal Code (TMC) provides that all transactions with the City of Tacoma, wherever consummated, are subject to the City's Business and Occupation Tax. It is the responsibility of the Bidder/Proposer awarded the Contract to register with the City of Tacoma's Finance, Tax and License Division, 733 Market Street, Room 21, Tacoma, WA 98402-3768, 253-591- 5252. The City's Business and Occupation Tax amount shall not be shown separately but shall be included in the unit and/or lump sum prices bid.

D. Do not include Washington State Sales Tax or Federal Excise Tax in the prices quoted. Bidder/Proposer is responsible to determine the correct sales tax rate to be paid and include it in the appropriate blank on the RFB/RFQ/RFP page.

7. Increase or Decrease in Quantities/Extensions: The City reserves the right to increase or decrease the quantities of any item under this contract and pay according to the unit price in the RFB/RFQ/RFP. Unless otherwise specified in the solicitation, contracts resulting from this RFB/RFQ/RFP are subject to extension by mutual agreement at the same prices, terms and conditions.

8. Evaluation of Bids/Awards:

A. The City reserves the right to: (1) award bids/proposals received based on individual items or groups of items, or on the entire list of items (2) to reject any or all bids/proposals or any part thereof, and if necessary, call for new bids/proposals (3) to waive any informality in the bids/proposals, and (4) to accept the bid/proposal that is the lowest and the best bid/proposal in the interest of the City of Tacoma.

B. The City reserves the right to correct ambiguities and obvious errors in the Bidder/Proposer's proposal. In this regard, if the unit price does not compute to the extended total price, the unit price shall govern.

C. In the evaluation of bids/proposals, the Bidder's/Proposer's experience, delivery time, and responsibility in performing other contracts will be considered. In addition, the bid/proposal evaluation factors set forth in TMC Section 1.06.253 may be considered by the City as well as the tax revenue the City would receive from purchasing item(s) from a supplier or suppliers located inside or outside the boundaries of the City of Tacoma.

9. Approved Equivalents:

A. Unless an item is indicated "No Substitute," special brands, when named, are intended to describe the standard of quality, performance or use desired. Equivalent items will be considered by the City, provided that the Bidder/Proposer specifies the brand and model, and provides all descriptive literature, independent test results, product samples, etc., to enable the City to evaluate the proposed "equivalent."

B. The decision of the City as to what items are equivalent shall be final and conclusive. If the City elects to purchase a brand represented by the Bidder/Proposer to be an "equivalent," the City's acceptance of the item will be conditioned on the City's inspection and testing after receipt. If, in the sole judgment of the City, the item is determined not to be an equivalent, the item shall be returned at the Bidder/Proposer's expense and the contract canceled without any liability whatsoever to the City.

C. When a brand name or level of quality is not stated by the Bidder/Proposer, it is understood the offer is exactly as specified. If more than one brand name is specified, Bidder/Proposer must clearly indicate the brand and model/part number being bid/proposed.

10. Warranties/Guarantee: Bidder/Proposer warrants that all materials, equipment and/or services provided as a result of the RFB/RFQ/RFP shall be fit for the purpose(s) for which intended, for merchantability, and shall conform to the requirements and specifications of the RFB/RFQ/RFP; all items comply with all applicable safety and health standards established for such products by the Washington Industrial Safety and Health Act (WISHA), RCW Chapter 49.17, the U.S. Occupational Safety and Health Act (OSHA) and/or Consumer Products Safety Act, and all other applicable federal laws or agency rules; all items are properly packaged; and all appropriate instructions or warnings are supplied including any applicable MSDS sheets.

11. Legal Disputes: The sole venue of any legal action arising out of the Contract or any bids submitted in response to this RFB/RFQ/RFP shall be in the Pierce County Superior Court for the State of Washington and the interpretation of the terms of the Contract shall be governed by the laws of the State of Washington.

12. Contract Compliance Forms: TMC requires Bidder/Proposer's to submit proof and/or documentation of compliance with the City's requirements for equal economic opportunity and solicitation of Historically Underutilized Business subcontractors. If compliance forms are included with this RFB/RFQ/RFP, they must be fully and accurately completed and submitted at time of RFB/RFQ/RFP opening. Failure to do so may result in the bid/proposal being declared non-responsive. For compliance questions contact the City's Contract Compliance Office 747 Market Street, Tacoma, WA 98402, 253-591-5825.

13. Code of Ethics: TMC, Chapter 1.46, provides standards for certain unethical conduct by others including bidders and contractors. Violation of the City's code of ethics shall constitute a breach of contract, and will be grounds for termination of this contract.

14. Prevailing Terms and Conditions: Bidder/Proposer acknowledges and agrees that the terms and conditions stated herein shall control and prevail over any other conflicting terms and conditions Bidder/Proposer may present in connection with this Contract.

CUSHMAN DAMS
SUPPLY AND DELIVER
ANTIQUE ACORN STYLE LIGHT FIXTURES

Furnish and deliver 33 traditional acorn style fixtures with decorative cast aluminum fitters (polyester powder baked coating), and acrylic white acorn globes.

The fitters shall fit a 2.875" OD by 3" tall tenon for (as constructed) replacement concrete poles. Embedded 1-1/2" conduit will be cut to length as required by manufacturers fitter.

Fitters shall be basic design matching as close as possible original plain fixtures (photo attached) and shall secure to the pole with set screws

Lighting shall be LED directed to provide substantial portion of lumens downward while still illuminating the entire globe for aesthetics. Performance demonstrated by independent LM79-80 testing, minimum 50,000 hours to L70.

Fitters, globes and lights shall be (or approved equal):

Sternberg B750AW/5PPT(mod to fit 2.875" OD tenon)/XRLED-12L45T3-MDL14/BK,
(OWG, old world grey)

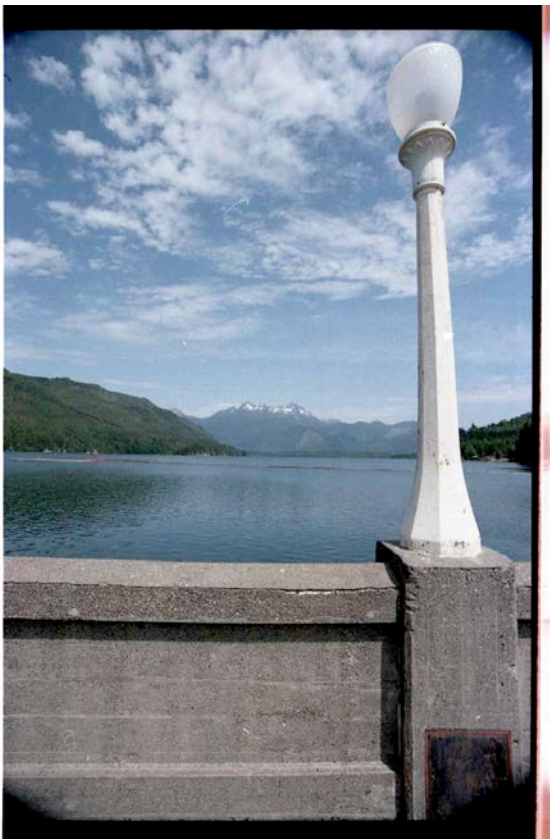

RUN CONDUIT LONG AT EA END AS REQ'D FOR CONCRETE FORMING-CUT END TO LENGTH PRIOR TO SHIPPING

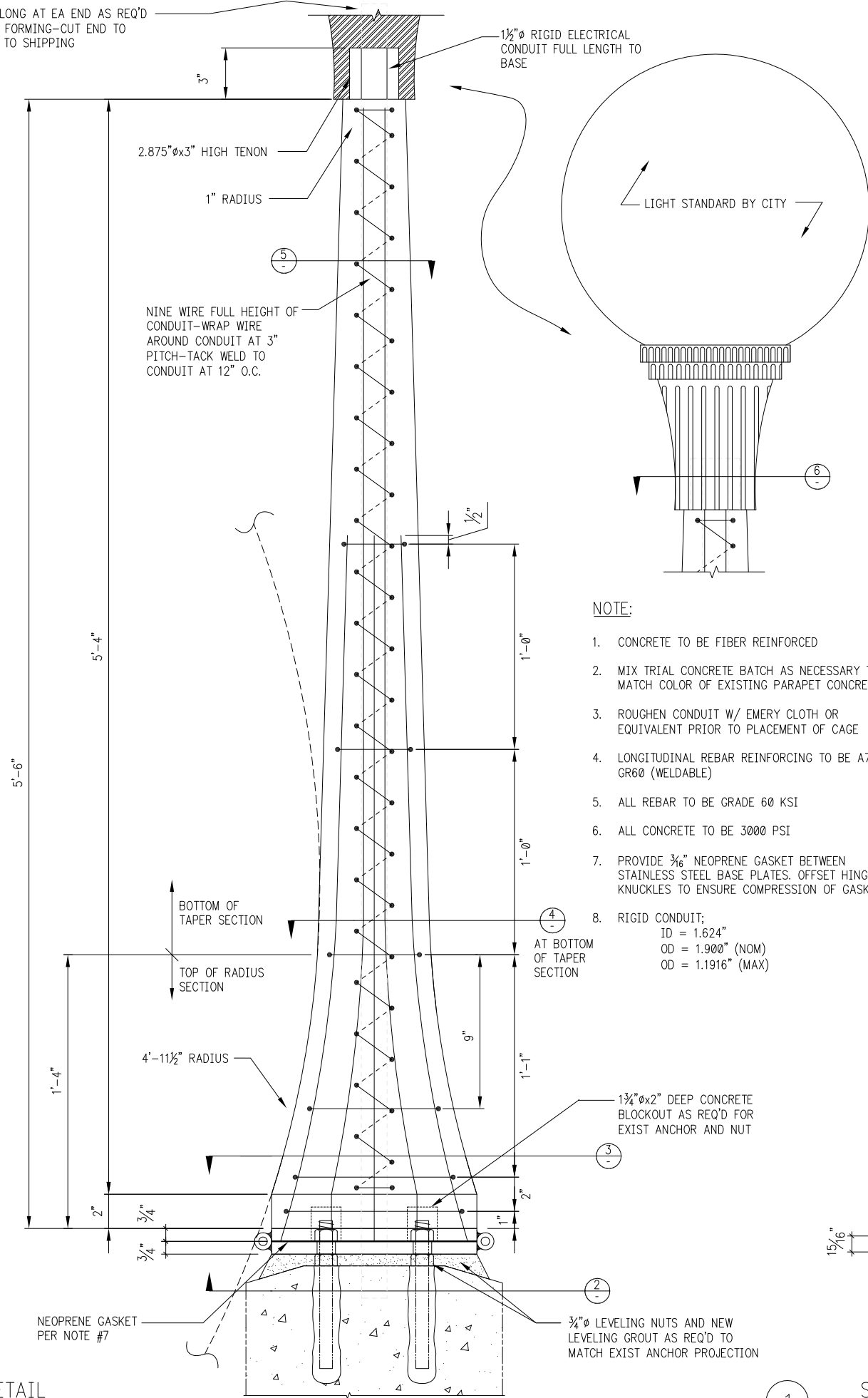

- NOTE:**
1. CONCRETE TO BE FIBER REINFORCED
 2. MIX TRIAL CONCRETE BATCH AS NECESSARY TO MATCH COLOR OF EXISTING PARAPET CONCRETE
 3. ROUGHEN CONDUIT W/ EMERY CLOTH OR EQUIVALENT PRIOR TO PLACEMENT OF CAGE
 4. LONGITUDINAL REBAR REINFORCING TO BE A706 GR60 (WELDABLE)
 5. ALL REBAR TO BE GRADE 60 KSI
 6. ALL CONCRETE TO BE 3000 PSI
 7. PROVIDE 3/16" NEOPRENE GASKET BETWEEN STAINLESS STEEL BASE PLATES. OFFSET HINGE KNUCKLES TO ENSURE COMPRESSION OF GASKET
 8. RIGID CONDUIT; ID = 1.624" OD = 1.900" (NOM) OD = 1.1916" (MAX)

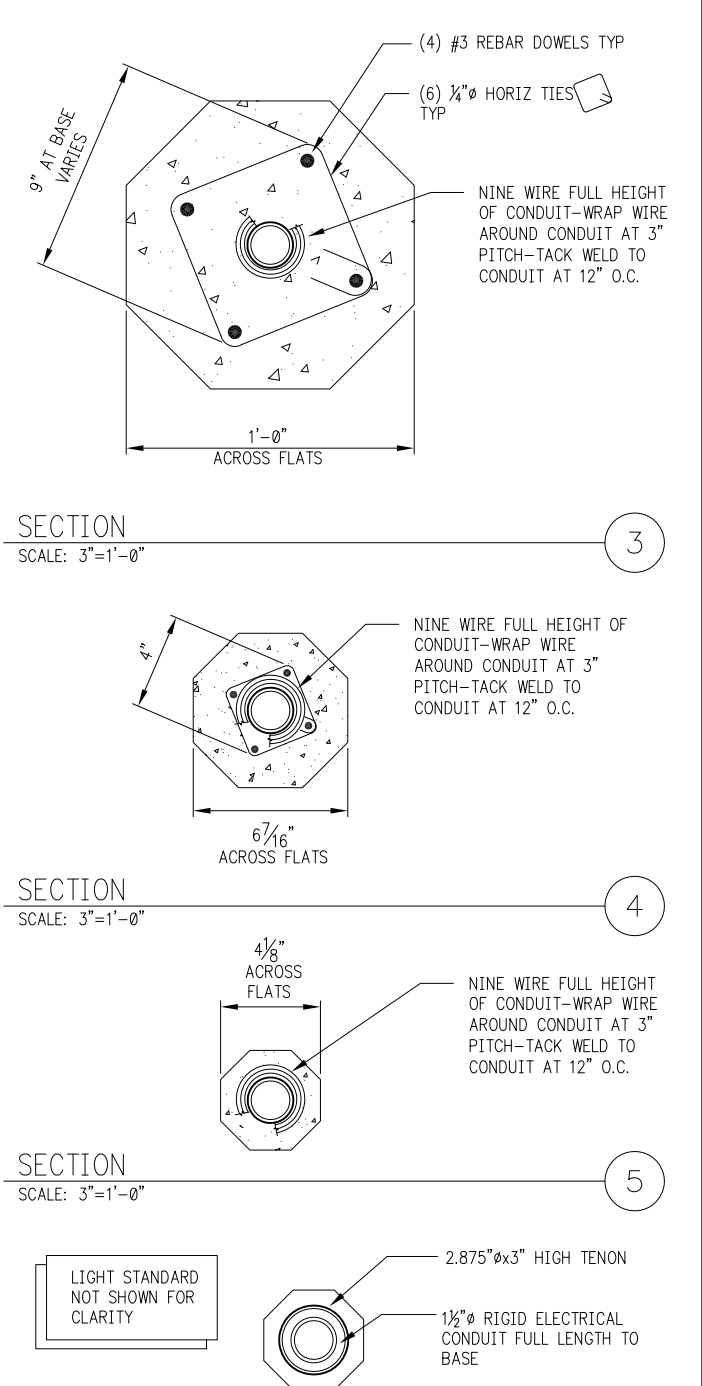
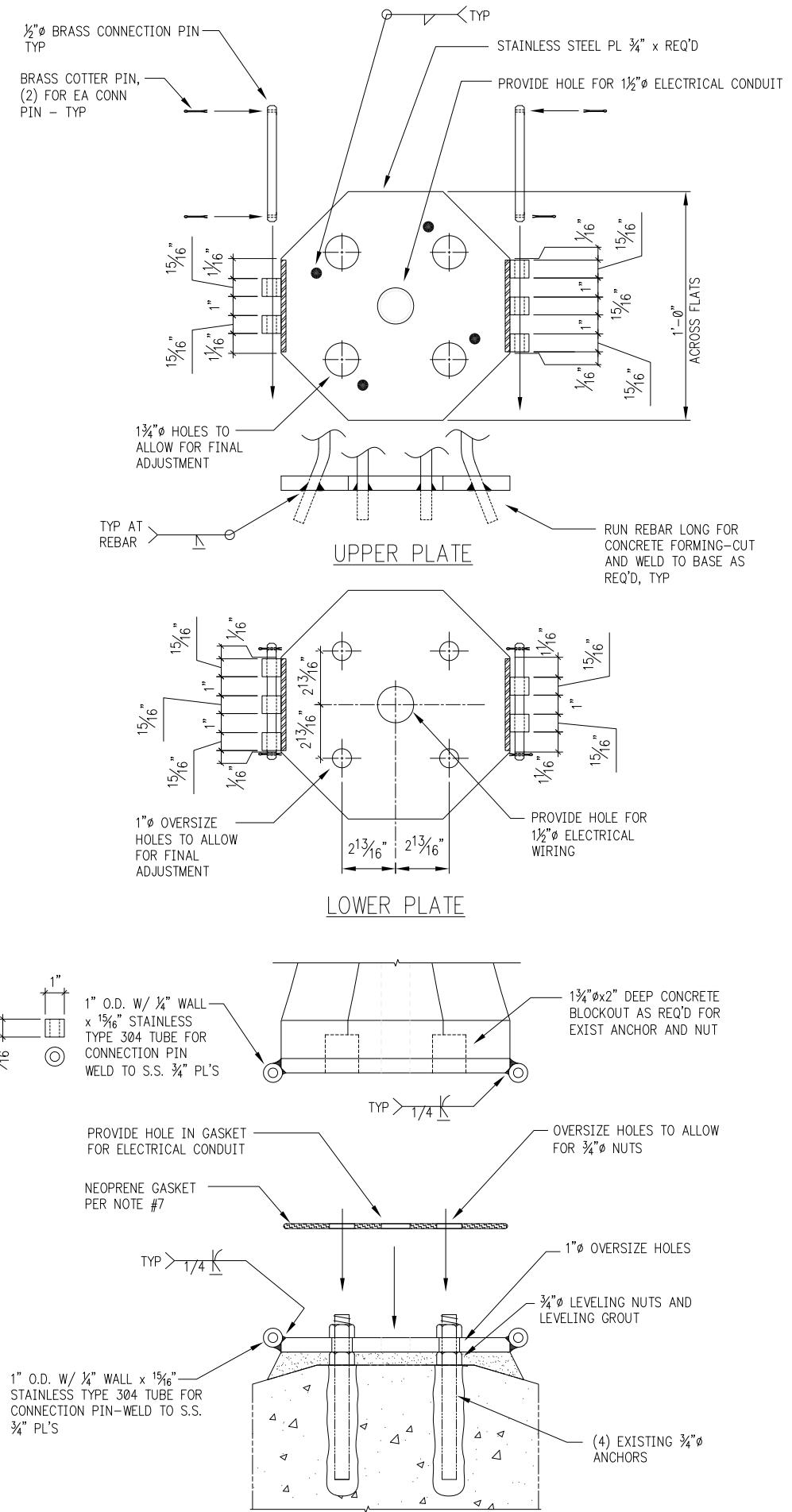

DETAIL
SCALE: 3"=1'-0"

SECTION
SCALE: 3"=1'-0"

SECTION
SCALE: 3"=1'-0"

0	3/2/11	ORIGINAL DRAWING	PAP	RCM	RCM
NO.	DATE	REVISION DESCRIPTION	DRAWN	CHECKED	STAMPED
CITY OF TACOMA DEPARTMENT OF PUBLIC UTILITIES LIGHT DIVISION					
CUSHMAN NO.1 & 2 DAM PARAPET WALL ORNAMENTAL LIGHTING STANDARD REPLACEMENT					
DESIGNED	RCM		FIELD BOOK		
APPROVED	KIRK J. KESSLER SUPERVISING ENGINEER		3/2/11	AS SHOWN	
APPROVED	STEVE H. FISHER APPROVING ENGINEER		DATE	SCALE	
DRAWN	CHECKED	REV. NO.	DRAWING NO.		
PAP		0	BA-053-1		
			SHEET OF		